

SICOLAB med

EN

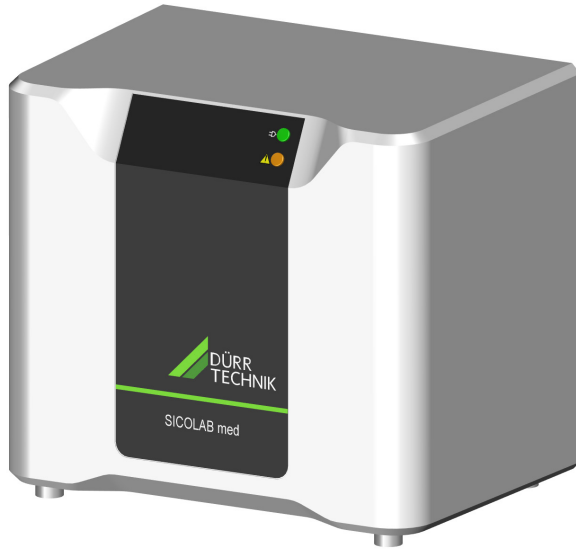

Installation and operating instructions

CE 0297

1018100100L02



 DÜRR
TECHNIK

1907V005

Contents



Important information

1 About this document	3
1.1 Warnings and symbols	3
1.2 Copyright information	4
2 Safety	4
2.1 Intended use	4
2.2 Improper use	4
2.3 General safety information	4
2.4 Specialist personnel	5
2.5 Electrical safety	5
2.6 Essential performance characteristics	5
2.7 Notification requirement of serious incidents	5
2.8 Only use original parts	5
2.9 Transportation and storage	6
2.10 Disposal	6



Product description

3 Overview	7
3.1 Scope of delivery	7
3.2 Spare parts and accessories	7
4 Technical data	8
4.1 Basic data	8
4.2 Variants	9
4.3 Declaration of conformity	10
5 Operation	11
5.1 Unit details	11
5.2 Pneumatics plan	12
5.3 Main air supply	13
5.4 Standby mode	13
5.5 Device label	14
6 Type plate	16



Assembly

7 Tools required	17
8 Requirements	17
8.1 Installation/setup room	17

8.2 Information regarding the pressure vessel	18
8.3 Pressure tank	18
8.4 Instructions for use for the pressure vessel (explanation by Behälter-Werk Burgau GmbH)	19

9 Commissioning	20
9.1 Remove the packaging	20
9.2 Unit with castors	20
9.3 Establishing the compressed air connection	20
9.4 Condensate	21
9.5 Electrical installation	21
9.6 Overtemperature protection	22



Usage

10 Operation	23
10.1 On/Off switch	23
10.2 Manual venting	23
10.3 Unit with castors	23
11 Maintenance	24
11.1 Maintenance schedule	24
11.2 Disinfecting and cleaning the surfaces	25



Troubleshooting

12 Tips for operators and service technicians	26
--	----



Appendix

13 Information about EMC in accordance with EN 60601-1-2	28
13.1 General notes	28
13.2 Abbreviations	28
13.3 Guidelines and manufacturer's information	28



Contact

14	Addresses	32
14.1	Returns / Repairs	32
14.2	To order spare parts	32
14.3	Service	32
14.4	Addresses worldwide	32

EN



Important information

1 About this document

These installation and operating instructions represent a part of the unit. They correspond to the relevant version of the unit and the status of technology valid at the time of its market launch.



In the event that the instructions and notes in these installation and operating instructions for are not observed, Dürr Technik accepts no warranty or liability of any kind for the safe operation and reliable function of the units.

This translation was prepared to the best of our knowledge. The original German language version of the manual is the definitive version. Dürr Technik is not liable for translation errors.

1.1 Warnings and symbols

Warnings

The warnings in this document are intended to draw your attention to possible injury to persons or damage to machinery.

The following warning symbols are used:



General warning symbol



Warning – dangerous high voltage



Warning – hot surfaces



Warning - automatic start-up of the unit

The warnings are structured as follows:



Description of the type and source of danger

Here you will find the possible consequences of ignoring the warning

- Follow these measures to avoid the danger.

The signal word differentiates between four levels of danger:

- **DANGER**
Immediate danger of severe injury or death
- **WARNING**
Possible danger of severe injury or death
- **CAUTION**
Risk of minor injuries
- **NOTICE**
Risk of extensive material/property damage

Other symbols

These symbols are used in the document and on or in the unit:



Note, e.g. specific instructions regarding efficient and cost-effective use of the unit.



Refer to Operating Instructions.



CE labelling with the number of the notified body



Manufacturer



Date of manufacture



Order number



Serial number



Dispose of correctly in accordance with EU Directive 2012/19/EU (WEEE).



Disconnect all power from the unit.



Protective ground connection



Air



Weight





Recycling





Orange warning LED "Temperature too high"

 AC current

 Green control LED "Unit ready for operation"

 Compressed air intake in bar / psi

 Compressed air outlet in bar / psi

 On / off switch in position "I": switch unit on

 On / off switch in position "O": switch unit off

 Fuses

 Tool Allen wrench

 Tool Hexagon wrench

 Tool Torque wrench

1.2 Copyright information

All names of circuits, processes, names, software programs and units used in this document are protected by copyright.

The reprinting of the installation and operating instructions, even in extracts, is only permitted with the written permission of Dürr Technik.

2 Safety

Dürr Technik has developed and constructed the units in such a way that danger is to a large extent excluded if the units are used as intended. Nevertheless, residual risks can remain. You should therefore observe the following notes.

2.1 Intended use

The unit is designed to provide compressed air for the supply of a respirator.

The unit aspirates ambient air. The aspirated ambient air must be suitable for the ventilation of patients and must not contain any harmful substances.

The compressed air generated by the unit is delivered directly to a ventilator. The unit can be used either as a replacement unit in standby mode or directly as the main air supply for a ventilator.

If the unit is used to supply air to life-sustaining ventilators, an adequate replacement supply must be provided as a backup in case of a defect on the unit

2.2 Improper use

Any other usage or usage beyond this scope is deemed to be improper. The manufacturer accepts no liability for damage resulting from such use. In such cases, the user/operator will bear the sole risk.

 **WARNING**
Danger of explosion from the ignition of flammable materials
› Do not operate the unit in any rooms containing flammable mixtures.

2.3 General safety information

- › When operating this unit, always observe all directives, laws, and other rules and regulations applicable at the site of operation.
- › Check the function and state of the unit prior to each use.

- › Do not convert or modify the unit.

- › Comply with the specifications of the Installation and Operating Instructions.

- › Ensure that the unit operator has access to the Installation and Operating Instructions at all times.



Should the user connect additional units to the respiratory air compressor, the resulting system is a medical device system.

It is the responsibility of the user to make sure that the medical device system meets the requirements of IEC 60601-1.



WARNING

The supply pressure of life-sustaining ventilators is too low.

Should the respiratory air compressor supply the respirator unit with an insufficient amount of compressed air, this can result in a pressure drop in the ventilator and insufficient air supply to the patient.

- › The ventilator must have a suitable alarm signal.



WARNING

Malfunction of the device due to portable and mobile RF communication units (electromagnetic interference)

Portable and mobile RF communication units (including antennae cable and external antennae) generate electromagnetic fields. This can result in malfunction of the unit.

- › Keep a minimum distance of 30 cm between the unit (including power cord) and RF communication unit / accessories.

2.4 Specialist personnel

Operation

Unit operators must ensure safe and correct handling based on their training and knowledge.

- › Instruct or have every operator instructed in the handling of the unit.

Installation and repairs

- › Always arrange for any assembly work, readjustments, alterations, extensions, and repairs to be performed by Dürr Technik or by personnel authorised and trained by Dürr Technik. Qualified personnel are defined as those trained by Dürr Technik; who are familiar with the unit technology; and are aware of the dangers presented by the unit.

2.5 Electrical safety

- › Observe and comply with all the relevant electrical safety regulations when working on the unit.
- › Replace any damaged cables or plugs immediately.

2.6 Essential performance characteristics

The SICOLAB med unit does not have any essential performance characteristics in accordance with EN/IEC 60601-1 section 4.3. The unit is classified as **not life-sustaining**. An adequate replacement supply must be provided for the supply of a life-sustaining ventilator.

2.7 Notification requirement of serious incidents

The user / patient is required to report to the manufacturer and the competent authority of the Member State, in which the user and/or patient is established, any serious incident that has occurred in relation to the device.

2.8 Only use original parts

- › Only use accessories and special accessories that are specified or approved by Dürr Technik.
- › Only use original working and spare parts.



WARNING

Risk of explosion of the pressure vessel and pressure hoses

The unit is pressurised and may explode if you do not comply with the notice.

- › The pressure vessel and the pressure hoses must be vented before they are stored or transported.
- › Protect the unit from moisture during transportation.
- › Always transport the unit in an upright position.



Dürr Technik accepts no liability for damage resulting from the use of non-approved accessories, special accessories or any working parts or spare parts other than original parts.

The use of non-approved accessories, special accessories or non-genuine working parts / spare parts (e.g. power cord) can have a negative effect on the electrical safety and EMC.

2.9 Transportation and storage

The original packaging provides optimum protection for the unit during transport.



Dürr Technik will not accept any responsibility or liability for damage occurring during transport due to the use of incorrect packaging, even where the unit is still under guarantee.

- Only transport the unit in its original packaging.
- Keep the packing materials out of the reach of children.

The unit may be stored in its original packaging

- in warm, dry and dust-free rooms;
- protected from contaminants.



If possible, retain the packaging material.

Ambient conditions during storage and transport

Ambient conditions during storage and transport

temperature	°C	-20 to +70
Rel. humidity	%	0 to 99
Air pressure	hPa	100 to 1100

Please refer to the labels on the packaging padding.

2.10 Disposal

Unit



The unit must be disposed of properly. Within the European Union, the unit must be disposed of in accordance with EU Directive 2012/19/EU (WEEE).

- › Please contact Dürr Technik if you have any questions regarding the proper disposal of the unit.

Packaging



Dispose of the packaging material in an environmentally responsible manner.

- Note current disposal routes.
- Keep the packing materials out of the reach of children.



3 Overview

3.1 Scope of delivery

The following items are included in the scope of delivery (possible variations due to country-specific requirements and/or import regulations):

Product name	Article number
SICOLAB med	1018xxxxxx
Power cord	
Installation and Operating Instructions.....	1018100100

3.2 Spare parts and accessories

Unit feet	1018100132
Castors.....	1018100126
Trolley	1018100070

4 Technical data

4.1 Basic data

Electrical data	Basic unit	
Nominal pressure	bar / MPa	3 / 0.3

General data		
Pressure vessel volume	L	3
Delivery quantity at 3 bar (0.3 MPa)	l/min	30
Duty cycle	%	100
Operating pressure, max.	bars	Max. 5
Switch-on/cut-off pressure(on standby)	bars	2.7 ± 0.2 to 3.2 ± 0.2
Supply pressure (standby mode)	bars	2.7 - 6
Safety pressure PS	bars	8
Type of protection	IP	IP20
Continuous flow	-	min. 30 L/min at 3.0 bar (the continuous flow depends on the ambient pressure. The actual minimum flow decreases at the ratio of ambient pressure/1013 mbar.)
Peak flow		180 L/min for max. 0.8 sec .
Dew point reduction at operating pressure		5°C at ambient temperature at ≥ 30 L/min. and max. ambient temperature of 40 °C. 15°C at ambient temperature at 15 L/min. and max. ambient temperature of 40 °C
Air quality		Dust- and oil-free compressed air
Sub-micro filter	µm	≤ 0.3
Noise level (at nominal pressure)	dB (A)	47
Weight	kg	40
Dimensions (L x W x H)	mm	348 x 515 x 440

Ambient conditions during ongoing operation		
temperature	°C	+5 to +40
Air pressure	hPa	500 to 1060
Rel. humidity	%	0 - 95

Classification		
Medical Devices Directive (93/42/EEC)		Class IIb

4.2 Variants

Nominal voltage V	Electrical fre- quency Hz	Nominal current A	Output P1 (kW)	Fuses IEC 127-2/V
Units without transformer				
220-240	50	2.2	-	T4H250V
Units with transformer				
220-230	60	2.4	-	T4H250V
115-120	50 or 60	4.7	-	T8H250V
127	50 or 60	4.2	-	T8H250V
110	50 or 60	4.8	-	T8H250V
100	50 or 60	5.4	-	T8H250V

EN

4.3 Declaration of conformity

Manufacturer's name:	Dürr Technik GmbH & Co. KG
Manufacturer's address:	Pleidelzheimer Straße 30 D-74321 Bietigheim-Bissingen
Reference number:	1018
Article designation:	SICOLAB med
From the serial number:	H400000

We hereby declare that the product described above conforms to the requirements of the valid version of the Medical Devices Directive 93/42/EEC.

The device fulfills the requirements of the following pertinent directives:

- Simple pressure vessel directive 2014/29/EU
- RoHS directive 2011/65/EU

The company Dürr Technik GmbH & Co. KG bears the sole responsibility for issuing the declaration of conformity.

The conformity assessment procedure was performed in accordance with Appendix II and included the participation of the notified body, DQS Medizinprodukte GmbH, August-Schanz-Str. 21, D-60433 Frankfurt a.M. (identification number 0297).

This declaration applies to products placed on the market until 6 May 2024.
Bietigheim-Bissingen, 29/04/2019

Andreas Ripsam
Executive Board of Dürr Technik

Proof of signature in the
Original document held by Dürr Technik

5 Operation

If the **unit is to be used as the main source of air supply** for a ventilator, the pressure hose (not included in the scope of delivery) must be connected to the compressed air supply (10) of the unit and must be connected to the ventilator.

If the **unit is used in standby mode**, an **additional** pressure hose with connector (not included in the scope of delivery) needs to be connected to connector (11) of the unit and the wall outlet of the central compressed air system. In standby mode, the unit monitors the pressure in the central compressed air system:

If the pressure drops below 2.7 ± 0.2 bar, the unit automatically takes over the supply of compressed air to the ventilator connected to it. If the pressure in the central compressed air system rises above 3.2 ± 0.2 bar again, the unit switches off its supply and remains in standby mode.

5.1 Unit details

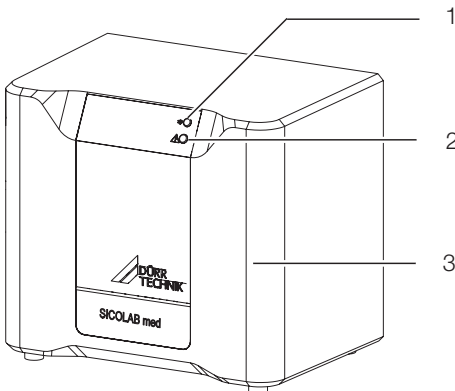

- 1 Green control LED "Unit ready for operation"
- 2 Orange warning LED "Temperature too high"
- 3 Cover of the unit

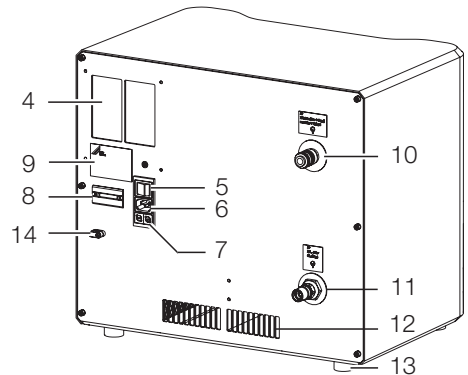

- 4 Filter mat
- 5 On/off switch
- 6 Power connection socket
- 7 Fuses
- 8 Operating time counter
- 9 Type plate
- 10 Compressed air supply¹⁾ of the ventilator (max. 5 bar)
- 11 Connection²⁾ for central compressed air supply (supply pressure) in standby mode (2.7 - 6 bar)
- 12 Cooling air vents
- 13 Unit feet / castors
- 14 Strain relief (for cables)

¹⁾Available versions: NIST connection; DISS connection; quick coupling NW 7.2

²⁾Available versions: NIST connection; DISS connection; G1/4" internal thread

5.2 Pneumatics plan

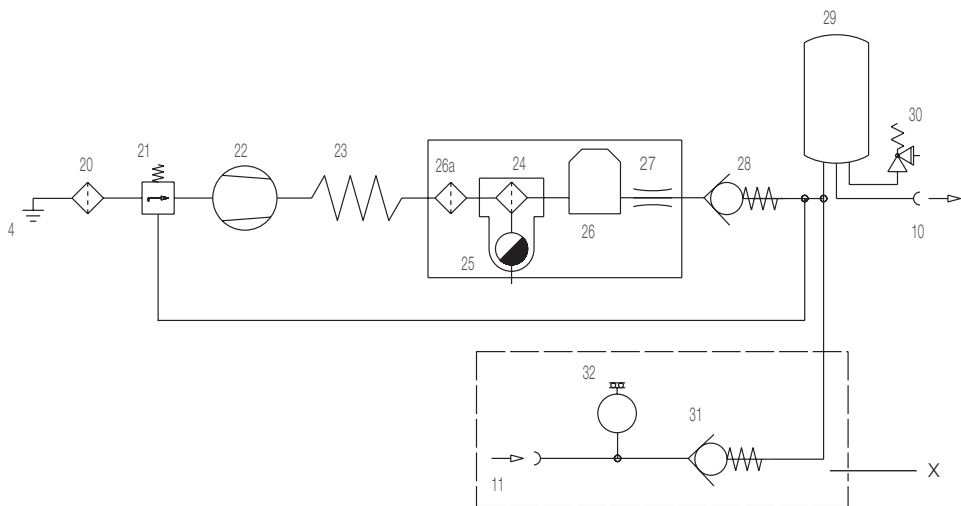

- 4 Filter mat (aspiration)
- 10 Compressed air connection for the ventilator
- 11 Connector for central compressed air supply in standby mode
- 20 Air intake filter
- 21 Regulating valve
- 22 Compressor unit
- 23 Cooler
- 24 Sub-micro filter 0.3 μm
- 25 Condensate separator
- 26 Membrane dryer
- 26a Fine filter 5 μm
- 27 Throttle nozzle
- 28 Check Valve
- 29 Pressure vessel
- 30 Safety Valve
- 31 Check Valve
- 32 Pressure switch
- X only required for standby mode

5.3 Main air supply

Ambient air is aspirated via the air intake filter on the regulating valve, compacted in the compressor and cooled in the cooler.

The compacted air is cleaned in the pre-filter, the condensate is separated in the condensate separator and discharged.

In the downstream membrane dryer, the air is dehumidified to a dew point of at least 5°C below ambient temperature.

The dehumidified air is guided via the throttle nozzle and check valve to the pressure vessel.

The dehumidified air is removed from the ventilator via the compressed air connection.

5.4 Standby mode

In standby mode, the ventilator is supplied from the central compressed air supply via the connection (11) with non-return valve. The compressor is in standby.

If the pressure in the central supply drops below 2.7 ± 0.2 bar, the pressure switch switches the compressor on.

If the pressure in the central supply rises to 3.2 ± 0.2 bar, the pressure switch switches the compressor off again.

The safety valve protects from excessively high pressure from the central supply.

The regulating valve is pressurised with the container pressure and regulates the generation of compressed air as a function of the volume removed.



The air from the central compressed air supply is not processed any further by the unit. It is necessary to use medical-grade compressed air free of hazardous substances and suitable for ventilation.

5.5 Device label

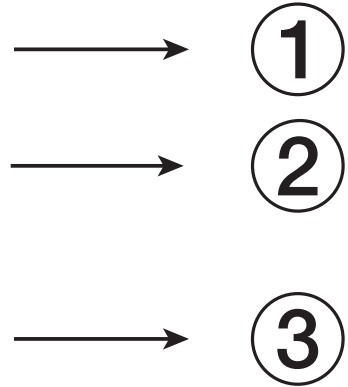
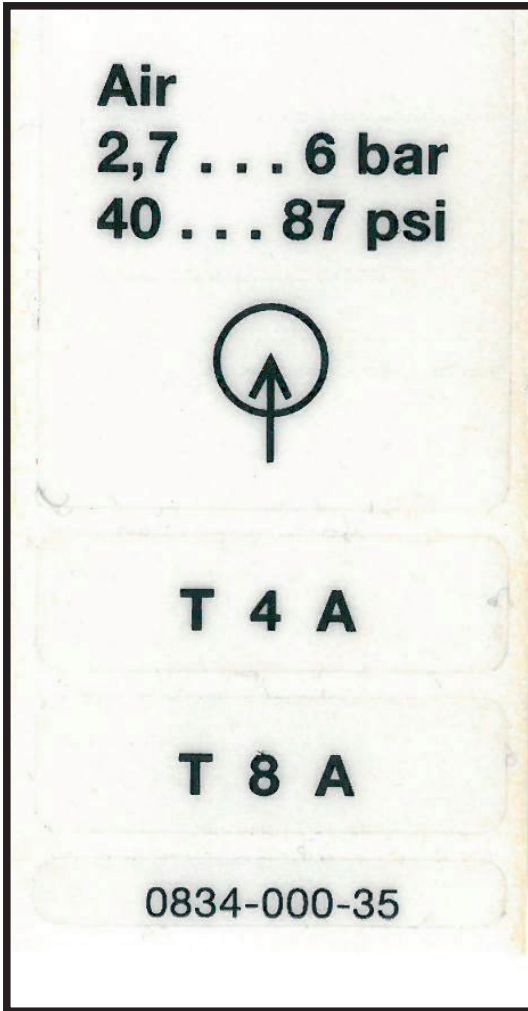

- 1 Medium
- 2 Supply pressure (max. 6 bar)
- 3 Compressed air input symbol

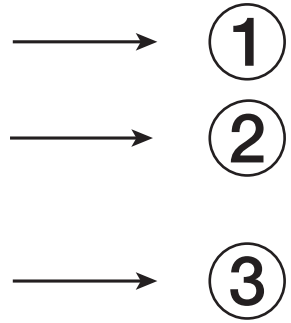
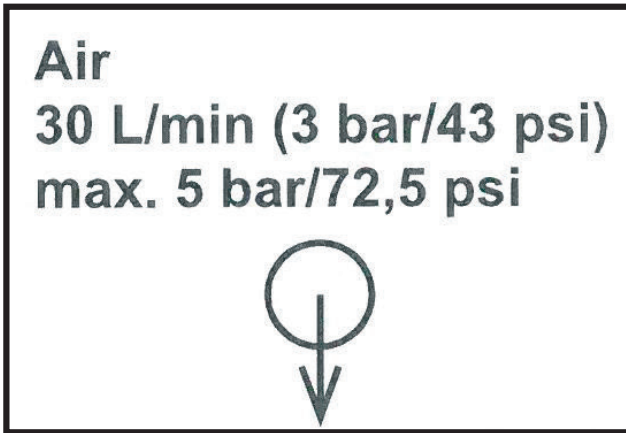

EN



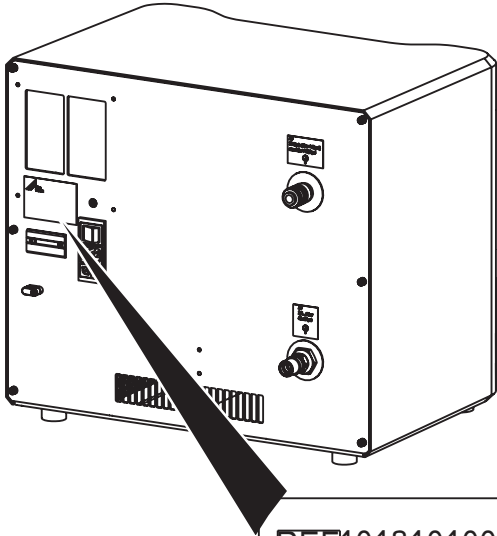

- 1 Medium
- 2 Operating pressure (max. 5 bar)
- 3 Compressed air outlet symbol

6 Type plate

The type plate is located on the rear of the unit.



EN



REF1018101001	SN DSKJ-0000	CE 0297
		
1018101001DSKJ-0000		IP: 20
V ~220-230	Hz 60	nom. 40 Kg (88 lbs)
A 2,4		
T4H250V		
5x20mm	IEC 127-2/V	 2017-08-23 <small>Date of manufacture</small>
 Duerr Technik GmbH&Co.KG Pleidelsheimer Str. 30 74321 Bietigheim-Bissingen Made in Germany		medium: 

REF Order number

SN Serial number



7 Tools required

-  Torque wrench
-  Hexagon key SW12
-  Allen wrench SW 3

8 Requirements

8.1 Installation/setup room

The room chosen for set up must fulfil the following requirements:

- Closed, dry, well-ventilated room.
- Should not be a purpose-made room (e. g. boiler room or wet room).
- Set up the unit on a clean, level and sufficiently stable surface (take the weight of the unit into account).
- Set up or install the unit so that the type plate can be easily read and the unit is easily accessible for operation and maintenance.
- Set up the units so that the socket to which the units is connected is easily accessible.
- Room temperature: +5°C to +40°C.
- Ensure that there is sufficient distance to the wall so that the air can flow in and out without any obstruction.



The air is filtered when it is sucked in. This does not alter the composition of the air. The source of the air taken in should be free of any harmful substances (e.g. do not draw in air from an underground garage or directly next to a suction machine).



NOTICE

Risk of overheating due to insufficient ventilation

The units generates heat. Possibility of heat damage and/or reduced service life of the unit.

- › Do not cover the unit.
- › Air must be able to flow in and out unobstructed.
- › Ventilation openings must be sufficiently large.
- › Installed units may require an independent ventilation system in unfavourable cases.

The unit must only be operated on a stable, even base. The unit must not be used as a climbing aid. Danger of breakage!

8.2 Information regarding the pressure vessel



The owner must comply with the national directives.

The container of the unit is smaller than 250 bar L. Therefore, EU countries do not require a periodic safety inspection.

Those operating the device outside the EU must check the valid national directives pertaining to the container inspection and implement them if necessary.

8.3 Pressure tank

Pressure vessels from Behälter-Werk Burgau GmbH are installed in the unit.

The instructions for use given below apply to the following pressure vessel type:

Type	Pressure ¹⁾	Vessel ²⁾	APP ³⁾	c ⁴⁾	Remark ⁵⁾
316033/0834100014	PS 10 bars	V 3 L	A	c = 1.0 mm	2

For serial number and build year refer to the labelling on the vessel.

¹⁾ Pressure	Maximum operating pressure PS in bar
²⁾ Vessel	Vessel volume V in litres
³⁾ Application (APP)	A = Pressure vessel for compressors
⁴⁾ Corrosion allowance	c in mm
Maximum temperature	+100 °C
Minimum temperature	-10 °C
Medium	Air/nitrogen
⁵⁾ Remark	2: The vessel is capable of sustained operation within a pressure fluctuation range of 2.0 bar (20% PS)

8.4 Instructions for use for the pressure vessel (explanation by Behälter-Werk Burgau GmbH)

The pressure vessel must only be used in accordance with the aforementioned intended purpose and in accordance with the specified technical data. Other forms of use are not permitted for reasons of safety. The pressure vessel has been designed in accordance with Directive 2014/29/EU and has been manufactured as a single component without safety equipment for the application area detailed above.

The unit has been designed for internal pressure loads.

Before commissioning, the vessel must be fitted with the necessary safety equipment such as a pressure gauge and safety equipment designed to protect against overpressure, etc. These parts are not included in our scope of delivery.

No welding work or heat treatment may be carried out on the pressure-retaining walls of the vessel. It must be ensured that the internal pressure does not exceed the operating pressure PS specified in the labelling on the vessel during operation. However, this pressure may be temporarily exceeded by up to 10%. Vibration stress that would be damaging for the pressure vessel and corrosion on the vessel must be prevented using appropriate measures.

The assembly or installation of the pressure vessel must be carried out in such a way that safe use of the vessel is ensured (e.g. no rigid connection to the floor or machine base frame without vibration dampers).

The operating instructions to be provided by the equipment supplier must include the following information in accordance with the equipment fitted:

- a) Instructions for draining the condensate
- b) Instructions and information about maintenance to ensure safety of use

The supplier must also specify whether the pressure vessel, when fully equipped for operation, has to undergo an acceptance test before commissioning. The supplier/owner must observe the laws and regulations regarding the operation of the pressure vessel that apply in the country of operation.

The design is intended for predominantly static internal pressure loads and covers the following operating parameters:

1000 load changes from 0 to PS and capable of sustained operation within a pressure fluctuation range of 2.0 bar (20% PS)

Remarks: see "8.3 Pressure tank".

9 Commissioning

9.1 Remove the packaging

The unit is securely protected with packaging material to ensure safe transportation.

- › Remove the packaging material.
- › Check the unit for damage in transit.
- › Lift the unit off the floor.

9.2 Unit with castors

The castors are enclosed with the unit and need to be installed before commissioning the unit.

- › Place the unit on its side.
- › Fit the castors with wheel lock in the front boreholes on the underside of the unit.

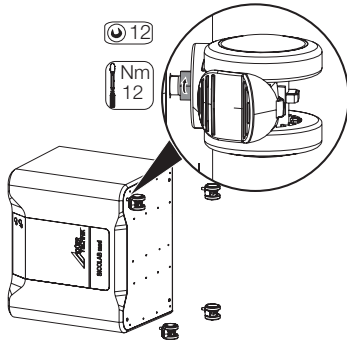

Figure 1: Install castor with wheel lock at the front borehole

- › Install the castors without wheel lock in the rear boreholes on the underside of the unit.

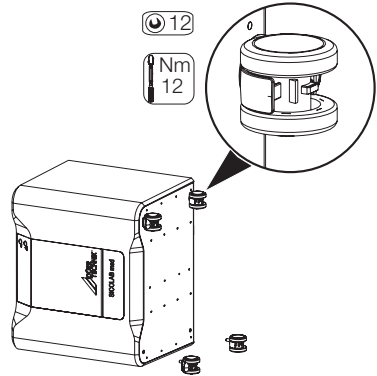
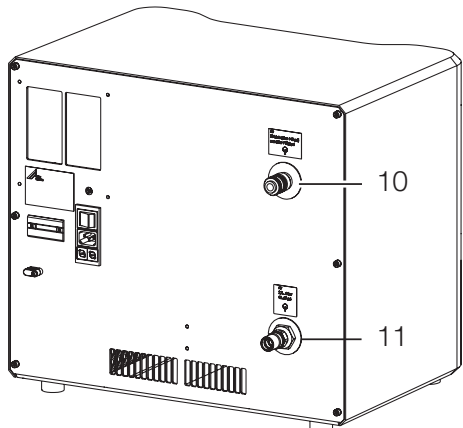

Figure 2: Install castor without wheel lock at the rear borehole

- › Screw the castors into the boreholes (clockwise) and tighten them (max. 12 Nm) with an AF 12 hexagon socket key.
- › Place the unit on the castors and check if all castors contact the floor and roll smoothly. Then close the wheel locks on the front castors and check if the unit is secured against rolling away.

9.3 Establishing the compressed air connection



10 Compressed air connection of the ventilator

11 Connector for central compressed air supply in standby mode

There are two compressed air connectors on the rear of the unit. The upper compressed air connection (10) is connected to the ventilator via a pressure hose. The compressed air connection is available as a NIST connection, DISS connection or a NW 7.2 quick coupling.

The lower connector (11) is connected to the central compressed air supply (e.g. to a wall outlet of the central compressed air system) for standby mode. This connection is available as a NIST connection, a DISS connection or a G1/4" internal thread.

Compressed air connection for the ventilator

The compressed-air connector is set to a pressure of 4.2 bar at the factory.

The pressure hose routed from the unit to the ventilator must not be routed through cool surroundings (e.g. placed on the floor). It may be routed to be as short as possible and without kinking. Otherwise there may be condensation in the pressure hose.

Connector for central compressed air supply



For units used in standby mode. This means for supply of the ventilator following outage of the central compressed air system.

- › Connect the flexible pressure hose to connector (11) on the rear of the unit and to the wall outlet of the central compressed air system.

9.4 Condensate

Any condensate is evaporated by an evaporation system.

9.5 Electrical installation



NOTICE Improper use of the power cord leads to malfunction

The enclosed power cord is intended exclusively for use with the delivered unit. If the power cord is used for other units, these units need to be monitored for proper function.

- › Use power cord for the delivered unit exclusively.



NOTICE

The use of a non-approved power cord can have a negative effect on the electrical safety and EMC.

The use of non-approved accessories, e.g. power cord, can give rise to increased electromagnetic emissions and/or reduced electromagnetic immunity.

- › Use original accessories (power cord) of the manufacturer exclusively.



If the power cord is missing or damaged, please contact Dürr Technik customer services or the distributor.

- › Plug the built-in plug (C14) of the power cord into the IEC socket (C13 according to IEC 60320) on the rear of the unit.
- › Tighten the strain relief anti-clockwise using the AF 3 Allen wrench.

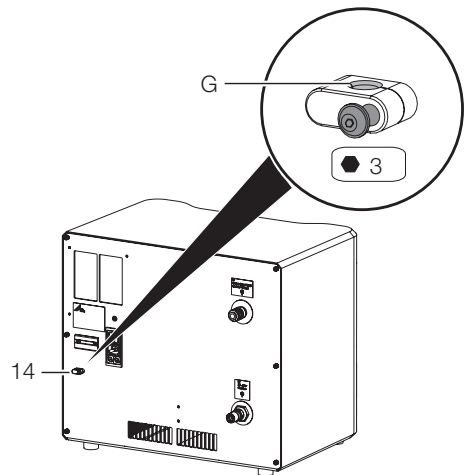

14 Strain relief

- › Guide the power cord through the strain relief without any mechanical stress and screw down the strain relief.

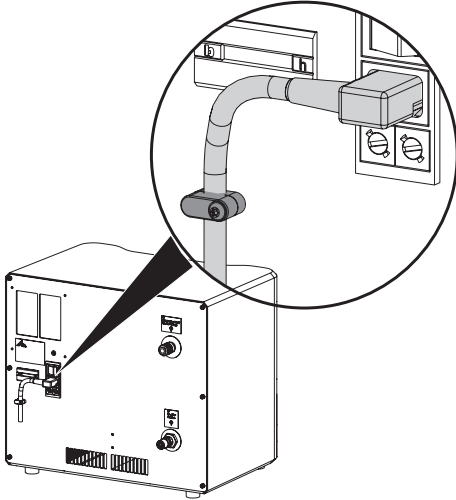

- › Connect the power cord plug to a properly installed mains socket outlet with PE conductor.
- › Route the power cord in such a way that it is not under any mechanical tension.
- › Before commissioning, verify that the power supply voltage complies with the voltage specifications of the type plate.



DANGER
Risk of electric shock due to damaged power cord or plug

Electric shocks can cause severe injuries.

- › Do not start up the unit if the power cord or plug is damaged.
- › Replace the damaged power cord.



DANGER
Electric shock due to missing protective earth

- › Connect the unit to the protective earth (PE) connection.



NOTICE
Automatic start-up of the unit after cooling down

- › Allow unit to cool down

The motors in the units are equipped with a temperature switch that switches the unit off if it overheats.

The orange warning LED "Temperature too high" is on and a permanent acoustic signal is issued. If this happens, you will first need to determine the cause of the fault and then remedy it, see "Troubleshooting".

9.6 Overtemperature protection



If the unit is switched off via the temperature switch, the fan of the unit will continue to run.



10 Operation

10.1 On/Off switch

- Move the on/off switch (5) on the rear of the unit to the "I" position to activate the unit.

The unit starts up and the pressure vessel is filled. Green indicator LED (1) on the front of the unit is on = ON.

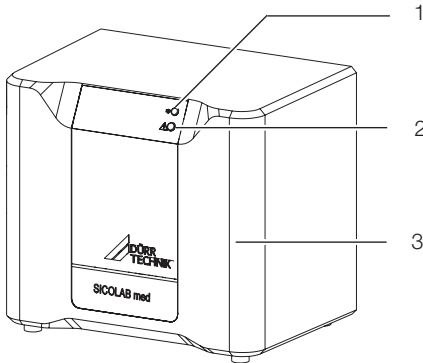

1 Green control lamp

- Set the on/off switch (5) to the "O" position to switch off the unit.

The green indicator lamp (10) is off = OFF.

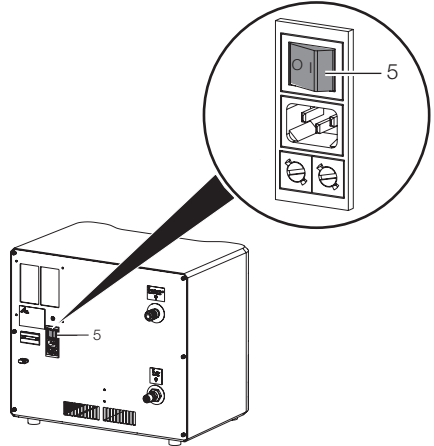

5 On/Off switch

-  The unit is not vented automatically. For venting, carefully disconnect the pressure hose from the ventilator. The remaining compressed air can be heard to escape.

10.2 Manual venting

Switch the unit off and disconnect it from the power supply. The unit is vented via the compressed air connection (10) for the ventilator (see "10.1 On/Off switch"). For this purpose, a compressed air gun can be connected to the compressed air connector and can be actuated until no air is replenished any longer.

10.3 Unit with castors

During operation, the castors of the unit must be secured against rolling away by the wheel locks.

11 Maintenance



De-energise the unit prior to working on it or in the event of potential danger (e. g. pull the mains plug) and prevent it from being switched back on again.



Perform an inspection and maintenance no later than after one year or 5000 operating hours. If needed, service the unit at shorter intervals.

Maintenance and repair work may be done only by Dürr Technik or Dürr Technik-qualified personnel/service engineers.

11.1 Maintenance schedule

Maintenance interval	Maintenance work
After 5000 operating hours / annually	› Maintenance by Dürr Technik-qualified service engineer/technician.

11.2 Disinfecting and cleaning the surfaces

The surface of the unit can be disinfected with disinfectant wipes. Preparations from the group of surface disinfectants should be used for this purpose. For reasons of materials compatibility, preparations based on the following agents are suitable:

- Aldehydes
- quaternary ammonium compounds.

The following preparations on the basis of:

- phenol-containing compounds
- halogen-releasing compounds
- strong organic acids
- oxygen-releasing compounds.

are not suitable because of possible damage to the materials.

We recommend the following disinfectants for cleaning the surfaces:

- B 60 Disinfectant wipes
- › Comply with the operating instructions for the disinfectant wipes.



12 Tips for operators and service technicians



Perform an inspection and maintenance no later than after one year or 5000 operating hours. If needed, service the unit at shorter intervals.

Maintenance and repair work may be done only by Dürr Technik or Dürr Technik-qualified personnel/service engineers.



De-energise the unit prior to working on it or in the event of potential danger (e. g. pull the mains plug) and prevent it from being switched back on again.

Fault	Probable cause	Solution
Unit does not start and indicator LED "Unit ready for operation" is off	No power supply voltage.	<ul style="list-style-type: none"> › Switch on the unit. › Check that the power supply matches the data on the type plate. › Check the mains plug. › Check the fuses on the power plug / replace them as required.
Unit does not start	Air intake filter blocked	› Contact service and insert a new air intake filter cartridge.
	Compressor is overloaded	<ul style="list-style-type: none"> › Disconnect the unit from the mains supply and allow it to cool down. › Reduce the ambient temperature. › Check that the application is suitable. › Contact customer service.
Unit too noisy / vibrates	Mechanical damage	› Contact customer service.
	Defective vibration dampers on compressor or unit	› Contact customer service.
Reduction in air flow	Air intake filter cartridge soiled	› Contact customer service. Have maintenance done.
	Soiled filter mat	› Contact customer service. Have maintenance done.
	Excessive ambient temperature	› Ensure that cooling is more effective.
	Unsuitable materials drawn in	› Only convey approved materials.
	Leakage on components of the unit	› Contact customer service.

Fault	Probable cause	Solution
The orange warning LED "Temperature too high" is on and a permanent acoustic signal is issued	ambient temperature too high	<ul style="list-style-type: none"> › Disconnect the unit from the mains supply and allow it to cool down. › Provide for unobstructed air circulation. › Reduce the ambient temperature.
	Soiled filter mat	<ul style="list-style-type: none"> › Contact customer service. Have maintenance done.
	Ventilation fan defective	<ul style="list-style-type: none"> › Contact customer service.
For standby mode: Unit starts up although the pressure in the central supply exceeds 2.7 ± 0.2 bar	Defective pressure switch	<ul style="list-style-type: none"> › Contact customer service.



13 Information about EMC in accordance with EN 60601-1-2

13.1 General notes

The information in this leaflet includes excerpts from the relevant European standards for electrical, medical devices. Comply with the information provided in this leaflet when you install and combine individual Dürr Technik units with products from other manufacturers. If you are uncertain about any details, please refer to the complete standard.

13.2 Abbreviations

EMC	Electromagnetic compatibility
HF	High frequency
U_T	Rated voltage of the device (supply voltage)
V_1, V_2	Compliance level for the test in acc. with IEC 61000-4-6
E_1	Compliance level for the test in acc. with IEC61000-4-3
P	Rated power of the transmitter in Watts (W) in accordance with the specifications of the transmitter manufacturer
d	Recommended safety distance in metres (m)

13.3 Guidelines and manufacturer's information

Resistance to electromagnetic interference (immunity) for all devices and systems

The unit is designed for use in the electromagnetic environments specified below. The customer or operator of the unit should ensure that it is operated in such environments.

Interference immunity tests	IEC 60601 - test level	Compliance level	Electromagnetic environment - guidelines
Electrostatic discharge (ESD) in accordance with IEC 61000-4-2	±8 kV contact discharge ±15 kV air discharge	±8 kV contact discharge ±15 kV air discharge	Floors should be made of wood or concrete, or covered with ceramic tiles. If the floor is covered by synthetic material, then the relative humidity must be at least 30%.
Fast transient electrical disturbance variables/burst in accordance with IEC 61000-4-4	±2 kV for power cords ±1 kV for input and output cables	±2 kV for power cords ±1 kV for input and output cables	The quality of the supply voltage should correspond to a typical commercial or hospital environment.
Voltage surge in accordance with IEC 61000-4-5	±1 kV voltage outer conductor-outer conductor ±2 kV voltage outer conductor earth	±1 kV push-pull voltage ±2 kV common mode voltage	The quality of the supply voltage should correspond to a typical commercial or hospital environment.

Interference immunity tests	IEC 60601 - test level	Compliance level	Electromagnetic environment - guidelines
Voltage drops, short-term interruptions and fluctuations of the supply voltage in accordance with IEC 61000-4-11	0 % U_T (100 % drop in the U_T) for 1/2 period 0% U_T (100% drop in U_T) for 5 periods 70% U_T (30% drop in U_T) for 25 periods 0 % U_T (100 % drop in the U_T) for 5 s	0 % U_T (100 % drop in the U_T) for 1/2 period 0% U_T (100% drop in U_T) for 5 periods 70% U_T (30% drop in U_T) for 25 periods 0 % U_T (100 % drop in the U_T) for 5 s	The quality of the supply voltage should correspond to a typical commercial or hospital environment. If the device operator needs the unit to continue working even if the mains power supply is interrupted, we recommend powering the device from an uninterruptible power supply (UPS) or a battery.
Magnetic field for a supply frequency (50/60 Hz) in accordance with IEC 61000-4-8	30 A/m	30 A/m	The magnetic fields at mains frequency should correspond to the typical values encountered in a commercial and hospital environment.

Table 1: Immunity to electromagnetic interference for all units and systems

Electromagnetic interference immunity for devices or systems that are not life-sustaining

Portable and mobile communication devices should not be used any closer to the unit (including cables) than the recommended safety distance, which is calculated based on the applicable formula for the transmission frequency.

Interference immunity tests	IEC 60601 - test level	Compliance level	Recommended safety distance
Conducted HF disturbance variables in accordance with IEC 61000-4-6	$3 V_{\text{eff}}$ 150 kHz to 80 MHz	$[V_1] = 3 \text{ V}$	$d = 1.2 \cdot \sqrt{P}$
Emitted HF disturbance variables in accordance with IEC 61000-4-3	3 V/m 80 MHz up to 2.7 GHz	$[E_1] = 3 \text{ V/m}$	$d = 1.2 \cdot \sqrt{P}$ for 80 MHz up to 800 MHz $d = 2.3 \cdot \sqrt{P}$ for 800 MHz up to 2.5 GHz

P Rated power of the transmitter in watts (W) in accordance with the specifications of the transmitter manufacturer

d Recommended safety distance in metres (m)



The field strength of stationary wireless transmitters should be lower than the compliance level for all frequencies based on investigations on-site^{a, b}.

Interference is possible in the environment of units that have the following symbols.

Comment 1 The higher frequency range applies for 80 MHz and 800 MHz.

Comment 2 These guidelines may not apply in all cases. The propagation of electromagnetic radiation is affected by absorption and reflection on buildings, objects and people.

^a The field strength of stationary transmitters, such as the base stations of mobile phones and land mobile radios, amateur radio stations, AM and FM radio and television broadcasters, for example, cannot be accurately predicted theoretically. In order to determine the electromagnetic environment with regard to stationary transmitters, a study of electromagnetic phenomena at the site should be considered. If the field strength measured at the location where the unit is used exceeds the compliance levels stated above, the unit should be monitored to verify that it works as intended. Additional measures, such as changing the orientation of the unit or moving it to a different location, may become necessary if unusual performance characteristics are observed.

^b Over the frequency range from 150 kHz to 80 MHz, the field strength should be less than $[V_1]$ V/m.

Recommended safety distance between portable and mobile HF communication devices and the unit

The device is designed for use in the electromagnetic environments specified below, in which the HF disturbance variables are controlled. The customer or the operator of the device can help to prevent electromagnetic interference by maintaining the minimum distances between mobile HF communication equipment (transmitters) and the device as recommended below in accordance with the maximum output line of the communication equipment.

Rated power of the transmitter (W)	Safety distance based on the transmission frequency (m)		
	150 kHz to 80 MHz	80 MHz to 800 MHz	800 MHz to 2.5 GHz
	$d = 1.2 \cdot \sqrt{P}$	$d = 1.2 \cdot \sqrt{P}$	$d = 2.3 \cdot \sqrt{P}$
0.01	0.12	0.12	0.23
0.1	0.38	0.38	0.73
1	1.2	1.2	2.3
10	3.8	3.8	7.3
100	12	12	23

Table 2: Recommended safety distance between portable and mobile HF communication devices and the unit

For transmitters whose maximum rated power is not specified in the table shown above, the recommended safety distance d in metres (m) can be determined from the formula that belongs to the respective column where P is the maximum rated power of the transmitter in watts (W) in accordance with the specifications of the transmitter manufacturer.

- Comment 1 The higher frequency range applies for 80 MHz and 800 MHz.
- Comment 2 These guidelines may not apply in all cases. The propagation of electromagnetic waves is affected by absorption and reflection on the building, objects and people.



14 Addresses

14.1 Returns / Repairs

Dürr Technik GmbH & Co. KG
Pleidelsheimer Straße 30
74321 Bietigheim-Bissingen
-Germany-



WARNING

Risk of explosion of the pressure tank and pressure hoses

› The pressure tank and the pressure hoses must be vented before they are stored or transported.



Use the original packaging when returning units, if possible. Always pack the units in a plastic bag. Use recyclable packing material.

14.2 To order spare parts

Tel. +49 (0) 71 42 / 9022 - 0
Fax +49 (0) 71 42 / 9022 - 99
E-mail: office@duerr-technik.de

The following information is required when ordering spare parts:

- Type designation and item number
- Order number as appears on the spare parts list
- Quantity required
- Exact shipping address
- Shipping information

14.3 Service

Tel. +49 (0) 71 42 / 90 22 - 20
Fax +49 (0) 71 42 / 90 22 - 99
E-mail: service@duerr-technik.de

14.4 Addresses worldwide

www.duerr-technik.eu

Dürr Technik GmbH & Co. KG
Pleidelsheimer Strasse 30
74321 Bietigheim-Bissingen
Germany
Fon: +49 7142-90 22 -0
www.duerr-technik.com
office@duerr-technik.de

